

Double-arm Boom Stand



Quality of Inspection

Light, ESD-protected

Industrial-type light double-arm boom stand with UNC 1/4"-20 mounting screw for Inspectis Digital Microscopes.

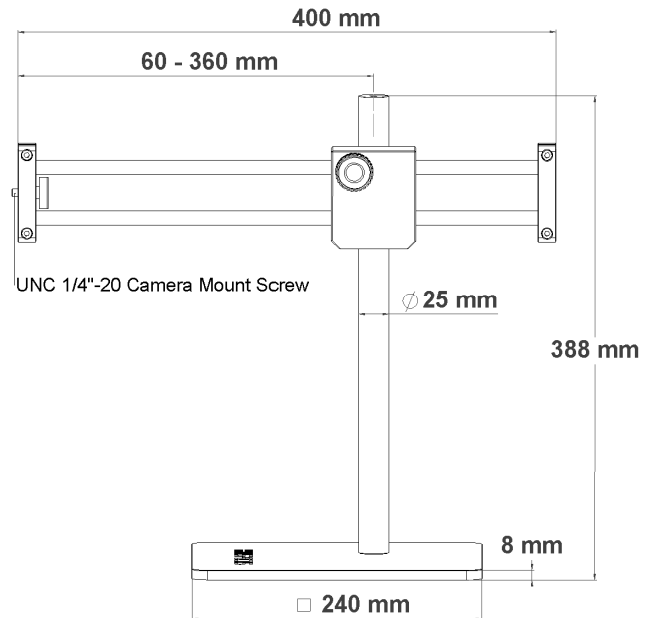
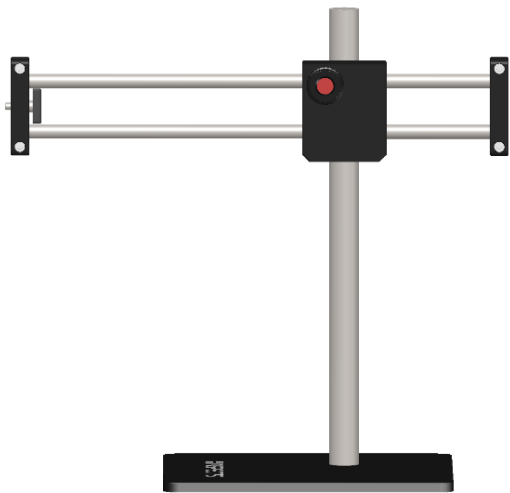

Solid metal 240mm x 240mm x 8mm base for excellent stability. Extended height versions available on request. Provides complete flexibility for horizontal, vertical and angular adjustment.

Specification:



Post length / Working Distance range:	380 mm / 0-300 mm
Boom length / Horizontal Travel range:	400 mm / 60-360 mm
Size / Weight of base:	240 x 240 x 8mm / 3.6 kg
Total Weight:	6.8 kg Max.
Others:	Knobs for position lock. ESD-protected

Ordering Number/Name

HD-071-E Double-arm Boom Stand, Light, ESD-protected
HD-071 Double-arm Boom Stand, Light

Compatible Accessories

HD-171 4-directional Tilt Unit for Inspectis Stands



Reseller: