

Double-arm Boom Stand, Light

Extended WD, ESD-protected



Quality of Inspection

Industrial-type light double-arm boom stand with UNC 1/4"-20 mounting screw, solid 240mm x 240mm x 8mm metal base and 500mm working distance for Inspectis Digital Microscopes.

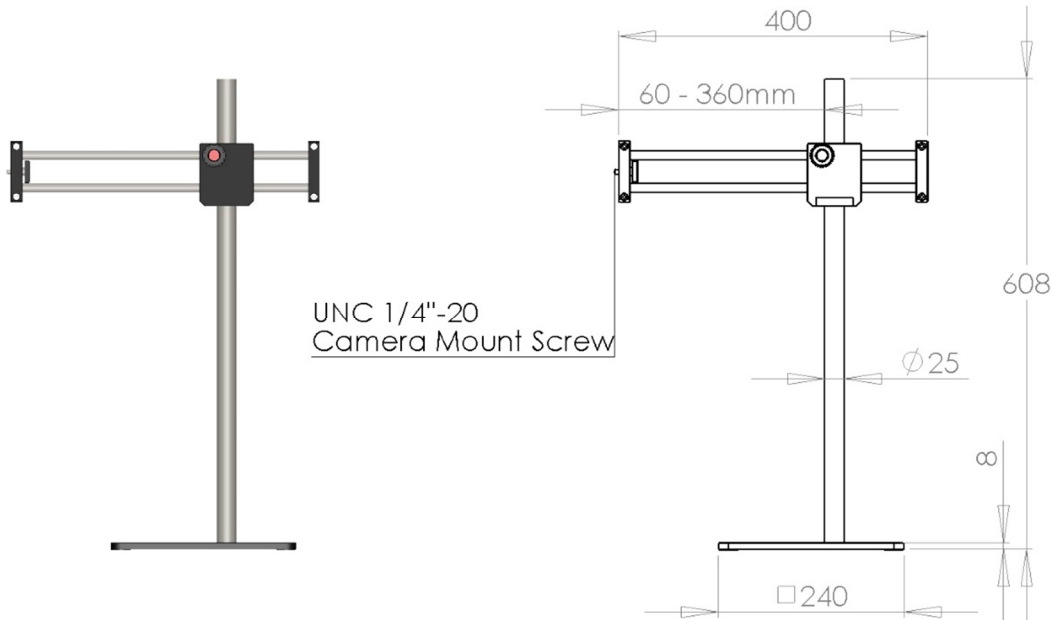

Stainless Steel rods and antistatic coated parts. Stop-Ring option for vertical position lock. Provides complete flexibility for horizontal, vertical and angular adjustment of digital microscope.

Specification:



Post length / Working Distance range:	600 mm / 0-500 mm Min.
Boom length / Horizontal Travel range:	400 mm / 60-360 mm
Size / Weight of base:	240 x 240 x 8mm / 3.6kg
Total Weight:	6.8kg Max.
Others:	Knobs for V- and H-position lock. ESD-protected

Ordering Number/Name

HD-071-E-EXT Double-arm Boom Stand, Light, Extended 500mm, ESD-protected
HD-071-EXT Double-arm Boom Stand, Light, Extended 500mm

Compatible Accessories

HD-171 4-directional Tilt Unit for Inspectis Stands
HD-075 Stop-Ring for Ø25mm Stand posts

Reseller:

