

# Single-arm Boom Stand

LWD, Large Base with PCB Holder



Quality of Inspection

Industrial-type boom stand with extended L630mm and  $\phi 25$ mm diameter vertical post and  $\phi 25$ mm L380mm boom in Stainless Steel that extends over the working area. Equipped with adjustable PCB holders and pegs for easy alignment of the boards under the microscope on the baseplate.

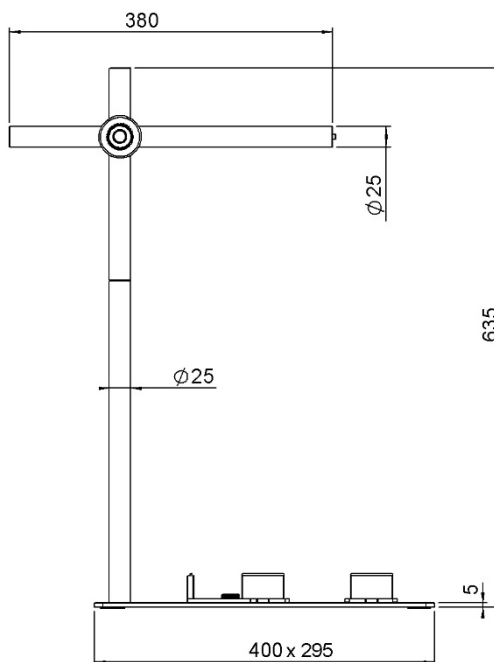

Provides complete flexibility for horizontal and vertical adjustment of Inspectis Digital Microscope. ESD-protected. Delivered with 5 pcs PCB holders and 4 pcs stainless steel pegs.

## Specification:

Vertical post length / Diameter / Travel:	635mm / $\phi 25$ mm / 590mm
Horizontal rod length / Diameter / Travel:	380mm / $\phi 25$ mm / 328mm
Size of base:	400x295x5mm
Weight:	9.2 kg



## Ordering Number/Name

HD-060-LWD-LB-E Inspectis Single-arm Boom Stand, LWD, Large Base with PCB Holder, ESD-Protected

## Compatible Accessories

- HD-182 VESA Monitor Holder for LWD Boom Stand
- HD-183 Stop Ring,  $\phi 25$ mm for Boom Stands

Reseller:

